



EASYLOAD

REVOLUTION IN LOADING



NO MORE HEAVY LIFTING!

Revolution in loading A World-First from MAD

The Dutch suspension specialist and brake disk aligning equipment manufacturer MAD, introduces a smart solution for loading light commercial vehicles: the MAD EasyLoad onboard loading system.

The MAD EasyLoad is set to drastically alter the daily routine for companies dealing with transport issues. From now on, heavy and difficult types of loads can be loaded and unloaded by just one person. Safely and quickly and with the minimum of effort.

New opportunities present themselves. What was extremely difficult to load until now, can now be handled with ease.

Invest in increased flexibility without costing the earth, and lighten the load for you and your personnel with the MAD EasyLoad.

Eases lifting loads and positioning them

The MAD EasyLoad stands out against all the other loading systems. Using the electrically powered extending boom you can easily lift loads up to 250 kg and then position them within the loading area of the vehicle. The boom and winch are operated electrically with a single press of the button. The handy mobile control unit can be operated very simply with one hand. You don't require any other equipment and you don't have to rely on the facilities available at the delivery or collection point.



Spare the backbone of your business

The MAD EasyLoad relieves drivers and employees and helps avoid Health & Safety at Work problems. Especially the avoidance of back complaints which crop up as a rule with repeated lifting and sliding heavy loads.

The MAD EasyLoad increases the flexibility and productivity of your fleet through improved loading capacity and vehicle deployment. In many situations a second man (driver's mate) is unnecessary.



The logo for MAD (MAD EasyLoad) is a yellow oval with the word "mad" in a bold, lowercase, sans-serif font. The "a" has a small registered trademark symbol (®) to its upper right.

MAD EasyLoad sideways shift

The MAD EasyLoad can also be shifted sideways. After use, you can push it completely to the side of the vehicle, so this creates additional space in the vehicle. If the vehicle is equipped racking system, the sliding design allows the Easy Load "parked" above the interior racking. To use the MAD Easy Load slide it to the middle and let loading begin.



MAD EasyLoad loading system for light commercial vehicles

The MAD EasyLoad onboard loading system consists of a high quality, compact winch unit with extendable boom. The stable lightweight construction guarantees absolute reliability and is maintenance-free.

The installation couldn't be easier. The MAD EasyLoad is mounted on a lightweight, self-supporting sub-frame which is positioned by an attachment to the existing anchor points in the vehicle loading area. Only two cables have to be connected for the power supply from the vehicle – expensive modifications are unnecessary. When vehicles are exchanged, the MAD EasyLoad can easily be un-installed and re-installed again – thus avoiding wasted capital!

Custom-made sub-frames are available for most popular light commercial vehicles.

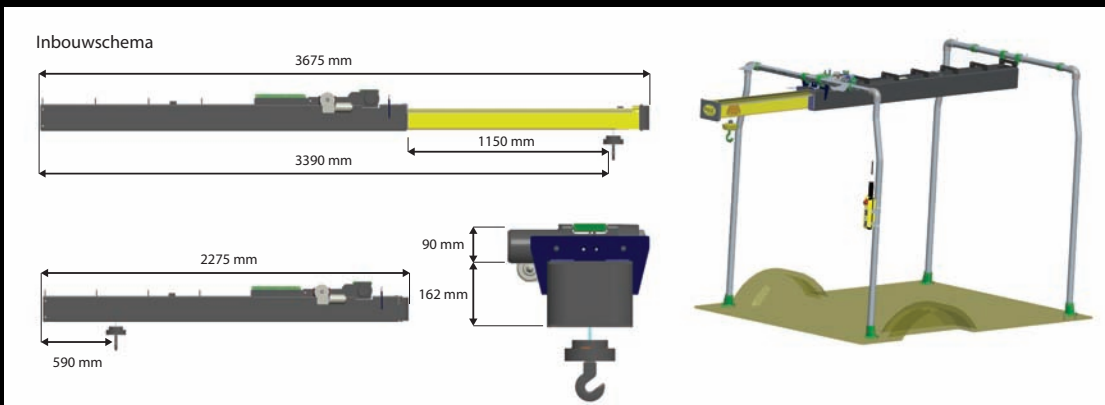

Technical data:	
Maximum lifting capacity:	250 kg
Length when retracted:	227,5 cm
Maximum load height:	300 cm (minus the height of the interior space)
Dead weight:	110 kg (including winch, but excluding Installation frame)
Winch specification:	12V 100A
Winch operation:	electric via pushbutton on hand-held unit
Slide system:	electric via pushbutton on hand-held unit
Lifting speed:	10 cm per second
Cable thickness:	ø 5 mm
Average installation time:	4 hours
Installation frames available:	Citroën, Fiat, Ford, Iveco, Mercedes, Nissan, Opel, Peugeot, Renault, Volkswagen etc.
Safety:	CE, NEN-EN-14492-2

MAD also supplies Powersprings, being an extensive system for all loading issues, as well as interactive air suspension systems. Further information from your workshop or dealer.